

LUX LED 1940 BY

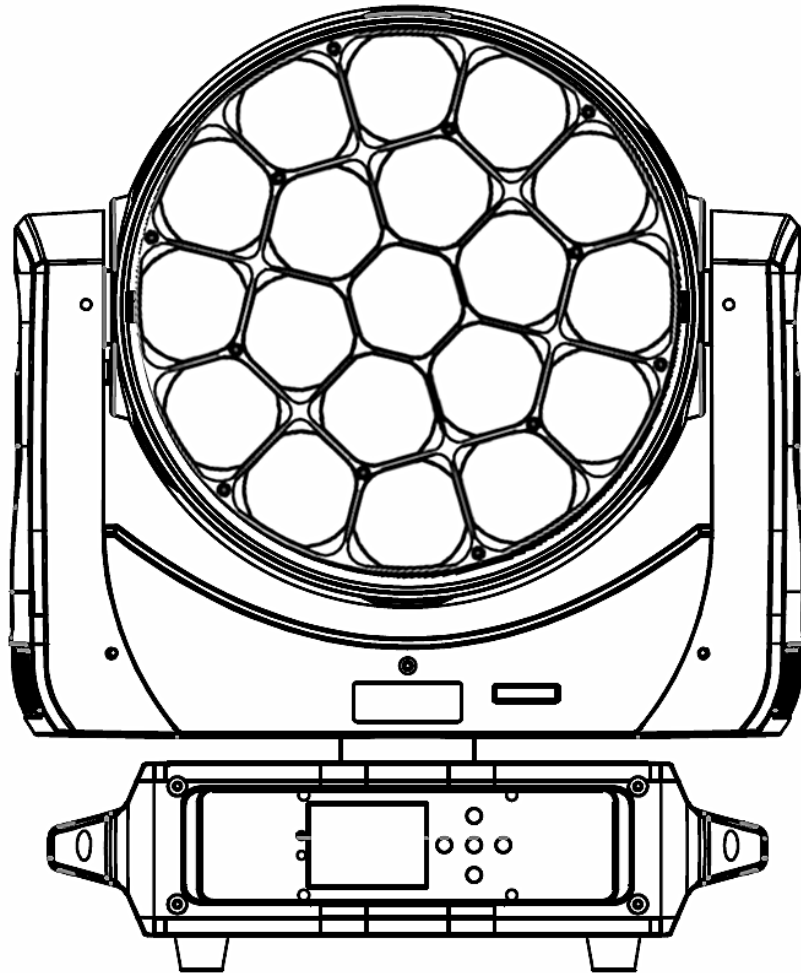

CE ∇ F \oplus IP20 LED $\left(\text{---} 0.2\text{m} \right) \left\| \right\| t_a 40^\circ\text{C} t_c 150^\circ\text{C}$

User Manual (V3.0)

KEEP THIS MANUAL FOR FUTURE NEEDS

1. Unpacking

Thank you for choosing our fixture. For your own safety, please read this manual before installing the device. This manual covers the important information on installation and applications. Please install and operate the fixture with following instructions. Meanwhile, please keep this manual well for future needs.

This fixture is made of a new type of high temperature strength of engineering plastics and cast aluminum casing with nice outlook. The fixture is designed and manufactured strictly following CE standards, complying with international standard DMX512 protocol. It's available independently controlled and linkable with each other for operation. And it is applicable for large-scale live performances, theater, studio, nightclubs and discos.

4-IN-1 LEDs(RGBW) which features high brightness and stability. Please carefully unpack it when you receive the fixture and check whether it is damaged during the transportation. And please check whether the following items are included inside the box:

Moving Head-----One Signal Cable----One
Hanging Bracket-----TwoPower Cable----One
Safety Cable-----one User Manual----One

2. Product dimension

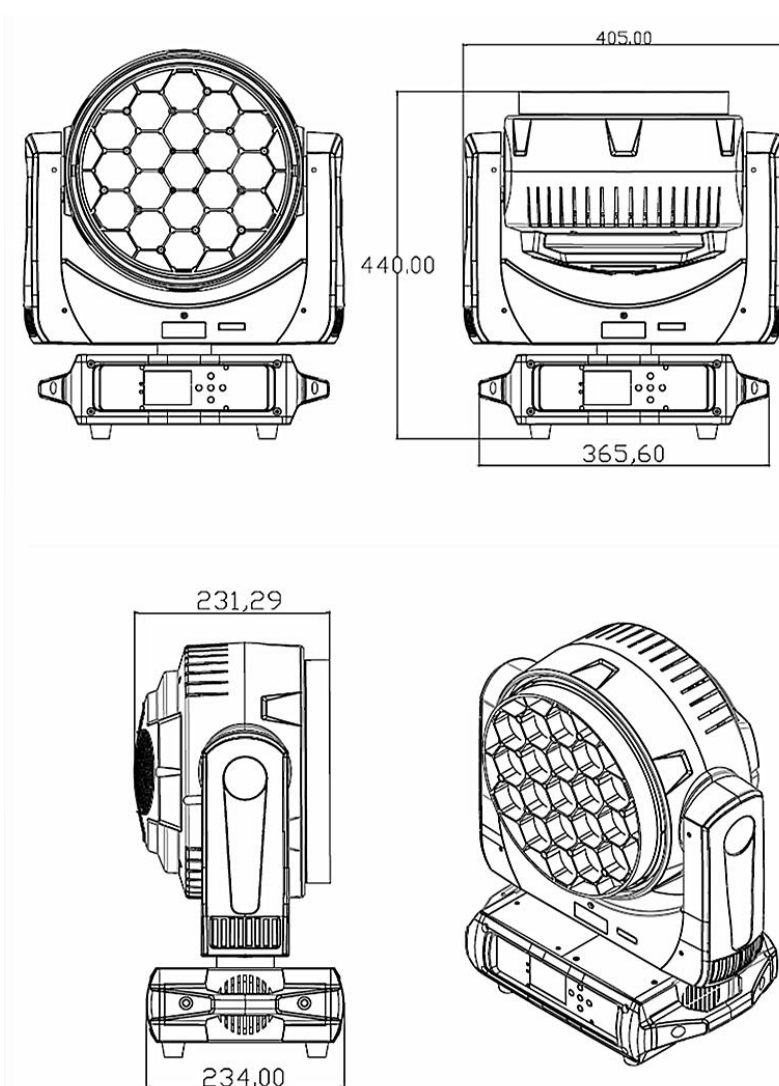

3. Safety Instructions



CAUTION!

Be careful with your operations. With a dangerous voltage you can suffer a dangerous electric shock when touching wires!

This device has left the factory in perfect condition. In order to maintain this condition and to ensure a safe operation, it is absolutely necessary for the user to follow the safety instructions and warning notes written in this user manual.



Important:

Damages caused by the disregard of this user manual are not subject to warranty. The dealer will not accept liability for any resulting defects or problems.

If the device has been exposed to temperature changes due to environmental changes, do not switch it on immediately. The arising condensation could damage the device. Leave the device switched off until it has reached room temperature.

This device falls under protection-class I. Therefore it is essential that the device be earthed.

The electric connection must carry out by qualified person.

The device shall only be used with rate voltage and frequency.

Make sure that the available voltage is not higher than stated at the end of this manual.

Make sure the power cord is never crimped or damaged by sharp edges. If this would be the case, replacement of the cable must be done by an authorized dealer.

Always disconnect from the mains, when the device is not in use or before cleaning it. Only handle the power cord by the plug. Never pull out the plug by tugging the power cord.

During initial start-up some smoke or smell may arise. This is a normal process and does not necessarily mean that the device is defective, it should decrease gradually.

Please don't project the beam onto combustible substances.

Fixtures cannot be installed on combustible substances, keep more than 50cm distance with wall for smooth air flow, so there should be no shelter for fans and ventilation for heat radiation.

If the external flexible cable or cord of this luminaire is damaged, it shall be exclusively replaced by the manufacturer or his service agent or a similar qualified person in order to avoid a hazard.

4. Operation Instructions

- The fixture is for beam wash and effect use.
- Don't turn on the fixture if it's been through severe temperature difference like after transportation because it might damage the light due to the environment changes. So make sure to operate the fixture until it is in normal temperature.
- This light should be kept away from strong shaking during any transportation or movement.
- Don't pull up the light by only the head, or it might cause damages to the mechanical parts.
- Don't expose the fixture in overheat, moisture or environment with too much dust when installing it. And don't lay any power cables on the floor. Or it might cause electronic shock to the people.
- Make sure the installation place is in good safety condition before installing the fixture.
- Make sure to put the safety chain and check whether the screws are screwed properly when installing the fixture.
- Make sure the lens are in good condition. It's recommended to replace the units if there are any damages or severe scratch.
- Make sure the fixture is operated by qualified personnel who knows the fixture before using.
- Keep the original packages if any second shipment is needed.
- Don't try to change the fixtures without any instruction by the manufacturer or the appointed repairing agencies.
- It is not in warranty range if there are any malfunctions from not following the user manual to operate or any illegal operation, like shock short circuit, electronic shock, lamp broke, etc.

5. Mounting and Installation

Cautions: For added protection mount the fixtures in areas outside walking paths, seating areas, or in areas where the fixture might be reached by unauthorized personnel.

Before mounting the fixture to any surface, make sure that the installation area can hold a minimum point load of 10 times the device's weight.

Fixture installation must always be secured with a secondary safety attachment, such as an appropriate safety cable.

Never stand directly below the device when mounting, removing, or servicing the fixture from a

periodic safety inspection of all installation material and the fixture. If you lack these qualifications, do not attempt the installation yourself. Improper installation can result in bodily injury.

Be sure to complete all rigging and installation procedures before connecting the main power cord to the appropriate wall outlet.

Clamp Mounting: The product provides a unique mounting bracket assembly that integrates the bottom of the base, the included “Omega Bracket,” and the safety cable rigging point in one unit (see the illustration below). When mounting this fixture to truss be sure to secure an appropriately rated clamp to the included omega bracket using a M10 screw fitted through the center hole of the “omega bracket”. As an added safety measure be sure to attached at least one properly rated safety cable to the fixture using on of the safety cable rigging point integrated in the base assembly

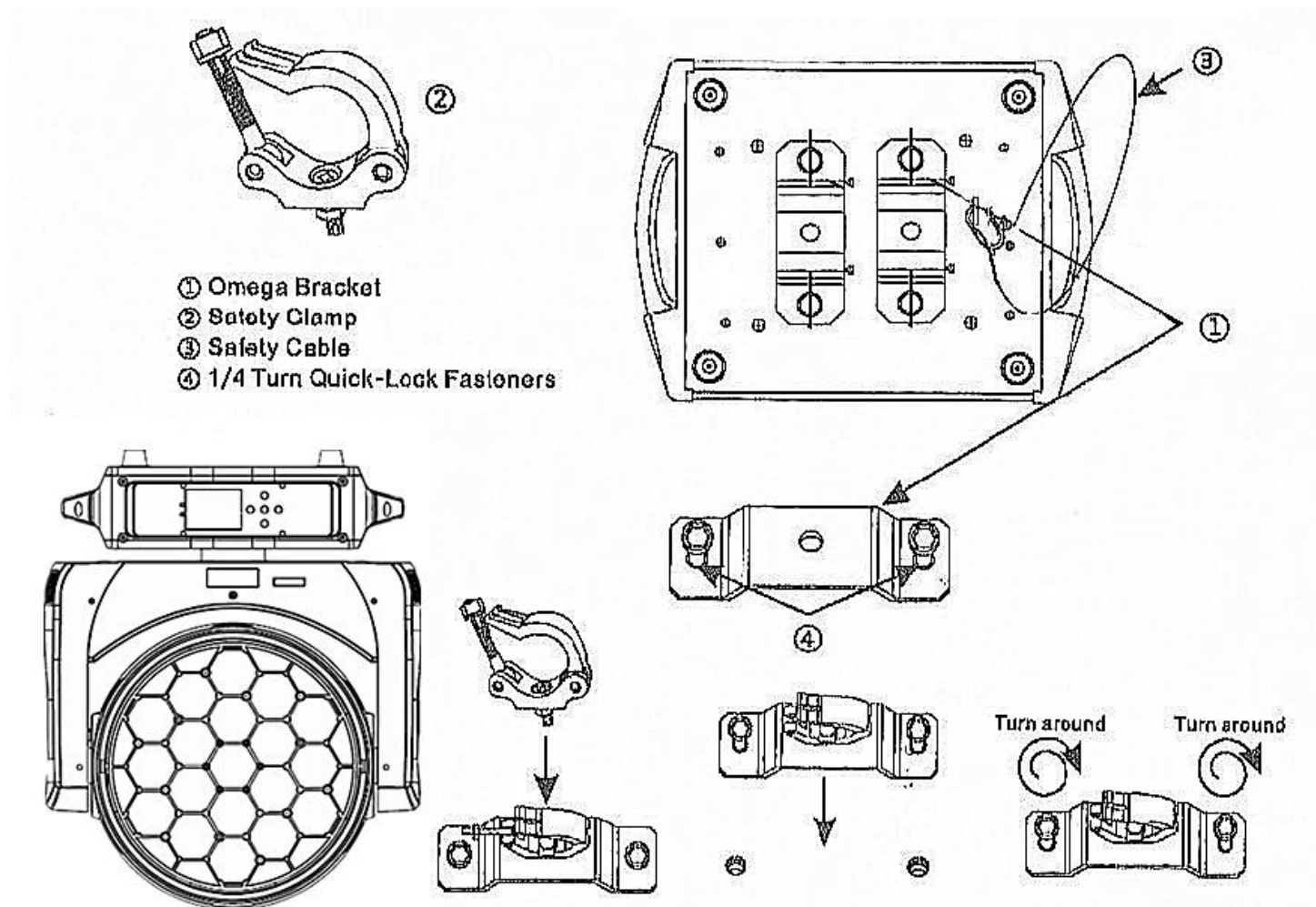

Regardless of the rigging option you choose for our fixture, always be sure to secure your fixture with a safety cable. The fixture provides a built-in rigging point for a safety cable on the hanging bracket as illustrated above. Be sure to only use the designated rigging point for the safety cable and never secure a safety cable to a carrying handle.

6. DMX-512 control connections

Connect the provided XLR cable to the female 3-pin XLR output of your controller and the other side to the male 3-pin XLR input of the moving head. You can chain multiple

Moving heads be connected together through serial linking. The cable needed should be two core, screened cable with XLR input and output connectors. Please refer to the diagram below.

DMX-512 connection with DMX terminator

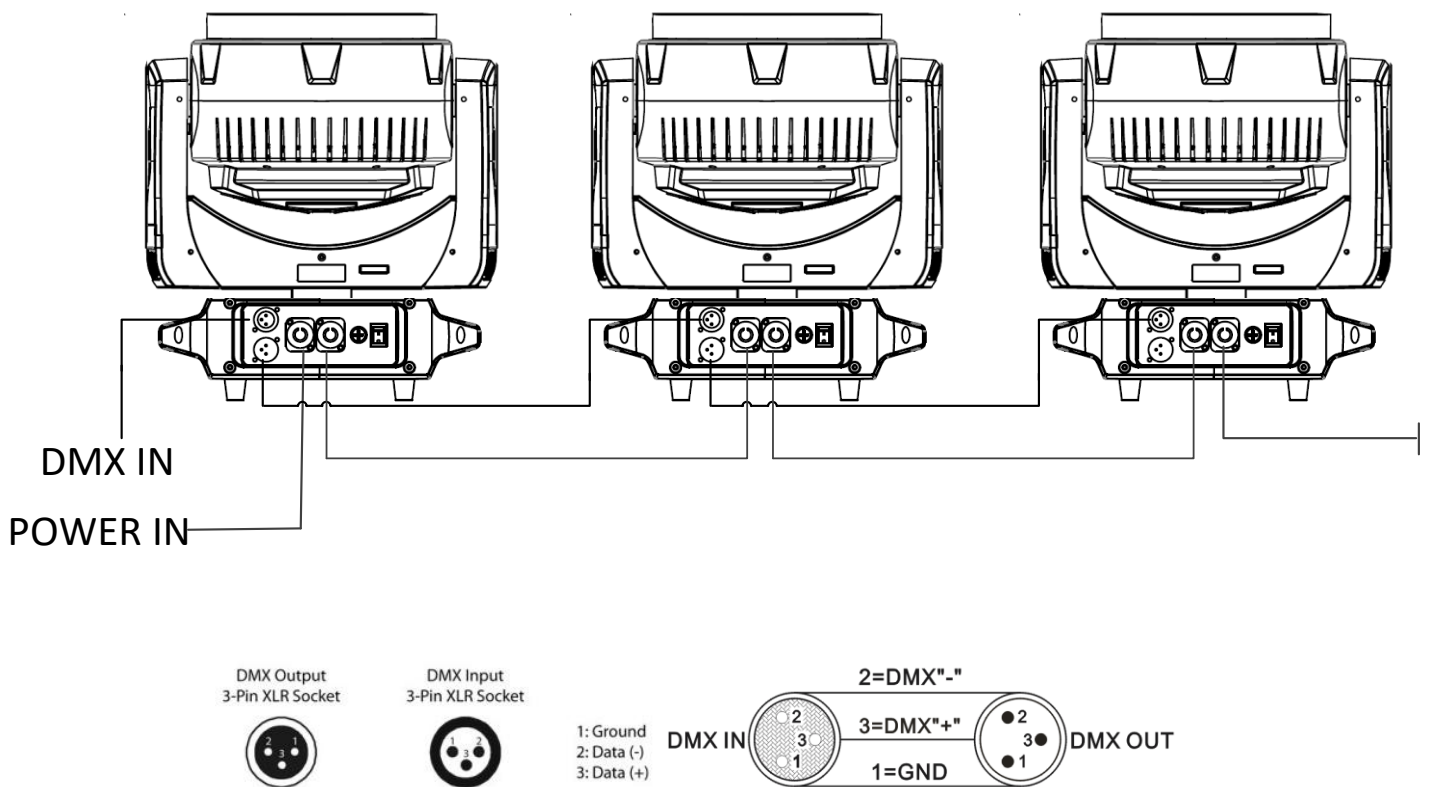

For installations where the DMX cable has to run a long distance or is in an electrically noisy environment, such as in a discotheque, it is recommended to use a DMX terminator. This helps in preventing corruption of the digital control signal by electrical noise. The DMX terminator is simply an XLR plug with a $120\ \Omega$ resistor connected between pins 2 and 3, which is then plugged into the output XLR socket of the last fixture in the chain. Please see illustrations below.

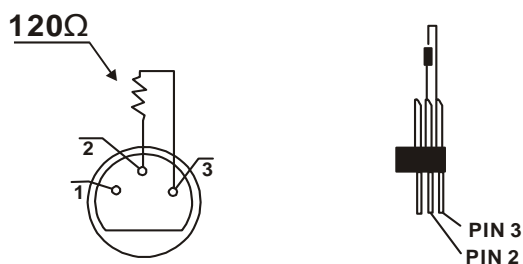

7. DMX Channels

21 channels mode

CH	Function	DMX Value	Details
1	Red	0-255	Red dimmer
2	Red Fine	0-255	Red fine control
3	Green	0-255	Green dimmer
4	Green Fine	0-255	Green fine control
5	Blue	0-255	Blue dimmer
6	Blue Fine	0-255	Blue fine control
7	White	0-255	White dimmer
8	White Fine	0-255	White fine control
9	CTO	0-9	No function
		10-255	Linear CTO
10	Macro color	0-255	Marco color control
11	strobe	0-3	No function, Light off
		4-103	Strobe with the same step from slow to fast
		104-107	No function, light up
		108-207	Pulse strobe from slow to fast
		208-212	No function, light up
		213-251	Random strobe from slow to fast
		252-255	No function, light up
12	Dimmer	0-255	0-100 linear dimmer from dark to bright
13	Dimmer Fine	0-255	Dimmer fine control
14	Pan	0-255	Pan movement control
15	Pan Fine	0-255	Pan fine control
16	Tilt	0-255	Tilt movement control
17	Tilt Fine	0-255	Pan fine control
18	Function	0-255	
19	Reset	0-25	No function
		26-76	Effect reset
		77-127	Pan/Tilt reset
		128-255	All reset with 5 seconds
20	Zoom	0-255	Zoom
21	Zoom Rotation	0-127	0 to 60 degree
		128-190	Unlimited anticlockwise rotation from fast to slow
		191-192	Stop
		193-255	Unlimited clockwise rotation from slow to fast

Remark: When CTO is activated, the RGBW and Macro color dimmer is not controllable.

30 channels mode

CH	Function	DMX Value	Details
1	Pan	0-255	Pan movement control
2	Pan fine	0-255	Pan fine control
3	Tilt	0-255	Tilt movement control
4	Tilt fine	0-255	Pan fine control
5	Pan/Tilt speed	0-255	Speed from fast to slow
6	ZOOM	0-255	Zoom
7	LENS rotation	0-127	0 to 60 degree
		128-190	Unlimited anticlockwise rotation from fast to slow
		191-192	Stop
		193-255	Unlimited clockwise rotation from slow to fast
8	Dimmer	0-255	0-100 linear dimmer from dark to bright
9	Strobe	0-3	No function, Light on
		4-200	Strobe with the same step from slow to fast
		201-255	Random strobe from slow to fast
10	R	0-255	1-100% Red linear dimmer from dark to bright
11	G	0-255	1-100% Green linear dimmer from dark to bright
12	B	0-255	1-100% Blue linear dimmer from dark to bright
13	W	0-255	1-100% White linear dimmer from dark to bright
14	Color temperature	0-9	No function
		10-255	Linear CTO
15	Marco	0-255	Marco color change
16	Static effect	0-9	No function
		10-184	Each 5 DMX value is a kind of static effect(35 kinds)
		185-255	36 th kind of static effect
17	Dynamic effect	0-9	No function
		10-229	Each 5 DMX value is a kind of dynamic effect(42 kinds)
		230-255	43 th kind of effect
18	Dynamic effect speed	0-127	Anti-clockwise rotate from fast to slow, operate against 17 CH
		128-255	Clockwise rotate from slow to fast, operate against 17 CH
19	Background R	0-255	Background color Red dimmer
20	Background G	0-255	Background color Green dimmer
21	Background B	0-255	Background color Blue dimmer
22	Background W	0-255	Background color White dimmer
23	LED ring dimmer	0-255	LED ring dimmer
24	LED ring strobe	0-4	No function, Light on
		5-250	LED ring strobe from slow to fast
		251-255	No function, Light on
25	LED ring Red	0-255	LED ring Red dimmer
26	LED ring Green	0-255	LED ring Green dimmer
27	LED ring Blue	0-255	LED ring Blue dimmer
28	LED ring macro	0-11	No function
		12-51	Every 2 DMX is one kind of macro color
		52-239	Every 4 DMX channel is one kind of dynamic effect(47 kinds)
		240-255	48 th kind of dynamic effect
29	Macro speed	0-255	LED ring macro effect from slow to fast
30	Reset	0-25	No function
		26-76	Effect reset
		77-127	Pan/Tilt reset
		128-255	All reset with 5 seconds

35 Channels mode

CH	Function	DMX Value	Details
1	Red	0-255	Red dimmer
2	Red Fine	0-255	Red fine control
3	Green	0-255	Green dimmer
4	Green Fine	0-255	Green fine control
5	Blue	0-255	Blue dimmer
6	Blue Fine	0-255	Blue fine control
7	White	0-255	White dimmer
8	White Fine	0-255	White fine control
9	CTO	0-9	No function
		10-255	Linear CTO
10	Macro color	0-255	Marco color effect
11	strobe	0-3	No function, Light off
		4-103	Strobe with the same step from slow to fast
		104-107	No function, light up
		108-207	Pulse strobe from slow to fast
		208-212	No function, light up
		213-251	Random strobe from slow to fast
		252-255	No function, light up
12	Dimmer	0-255	0-100 linear dimmer from dark to bright
13	Dimmer Fine	0-255	Dimmer fine control
14	Pan	0-255	Pan movement control
15	Pan Fine	0-255	Pan fine control
16	Tilt	0-255	Tilt movement control
17	Tilt Fine	0-255	Pan fine control
18	Function	0-255	Reversed channel, no function temporary
19	Reset	0-25	No function
		26-76	Effect reset
		77-127	Pan/Tilt reset
		128-255	All reset with 5 seconds
20	Zoom	0-255	ZOOM
21	LENS Rotation	0-127	0 to 60 degree
		128-190	Unlimited anticlockwise rotation from fast to slow
		191-192	Stop
		193-255	Unlimited clockwise rotation from slow to fast
22	Shape Selection	0-255	Selecting shape(8-70 workable)
23	Shape Speed	0-255	Shape speed control
24	Reversed	0-255	Reversed channel, no function temporary
25	Shape R	0-255	Shape in Red color
26	Shape G	0-255	Shape in Green color
27	Shape B	0-255	Shape in Blue color
28	Shape W	0-255	Shape in White color
29	Shape Dimmer	0-255	Shape dimmer 0-100%
30	Background	0-255	Background dimmer 0-100%
31	Shape Transition	0-255	Shape change
32	Shape Offset	0-255	Shape offset
33	Foreground	0-255	Foreground strobe control
34	Background	0-255	Background strobe control
35	Background	0-255	Background selection

43 Channels mode

CH	Function	DMX Value	Details
1	Red	0-255	Red dimmer
2	Red Fine	0-255	Red fine control
3	Green	0-255	Green dimmer
4	Green Fine	0-255	Green fine control
5	Blue	0-255	Blue dimmer
6	Blue Fine	0-255	Blue fine control
7	White	0-255	White dimmer
8	White Fine	0-255	White fine control
9	CTO	0-9	No function
		10-255	Linear CTO
10	Macro color	0-255	Marco color effect
11	strobe	0-3	No function, Light off
		4-103	Strobe with the same step from slow to fast
		104-107	No function, light up
		108-207	Pulse strobe from slow to fast
		208-212	No function, light up
		213-251	Random strobe from slow to fast
12	Dimmer	0-255	0-100 linear dimmer from dark to bright
13	Dimmer Fine	0-255	Dimmer fine control
14	Pan	0-255	Pan movement control
15	Pan Fine	0-255	Pan fine control
16	Tilt	0-255	Tilt movement control
17	Tilt Fine	0-255	Pan fine control
18	Function	0-255	Reversed channel, no function temporary
19	Reset	0-25	No function
		26-76	Effect reset
		77-127	Pan/Tilt reset
		128-255	All reset with 5 seconds
20	Zoom	0-255	ZOOM
21	LENS Rotation	0-127	0 to 60 degree
		128-190	Unlimited anticlockwise rotation from fast to slow
		191-192	Stop
		193-255	Unlimited clockwise rotation from slow to fast
22	Shape Selection	0-255	Selecting shape(8-70 workable)
23	Shape Speed	0-255	Shape speed control
24	Reversed	0-255	Reversed channel, no function temporary
25	Shape R	0-255	Shape in Red color
26	Shape G	0-255	Shape in Green color
27	Shape B	0-255	Shape in Blue color
28	Shape W	0-255	Shape in White color
29	Shape Dimmer	0-255	Shape dimmer 0-100%
30	Background	0-255	Background dimmer 0-100%
31	Shape	0-255	Shape change
32	Shape Offset	0-255	Shape offset
33	Foreground	0-255	Foreground strobe control
34	Background	0-255	Background strobe control
35	Background	0-255	Background selection
36	Reversed	0-255	Reversed channel, no function temporary
37	LED ring	0-255	LED ring dimmer
38	LED ring strobe	0-4	No function, Light on
		5-250	LED ring strobe from slow to fast
		251-255	No function, Light on
39	LED ring Red	0-255	LED ring Red dimmer
40	LED ring Green	0-255	LED ring Green dimmer
41	LED ring Blue	0-255	LED ring Blue dimmer
42	LED ring macro	0-11	No function
		12-51	Every 2 DMX is one kind of macro color
		52-239	Every 4 DMX channel is one kind of dynamic
		240-255	48 th kind of dynamic effect
43	Macro speed	0-255	LED ring macro effect from slow to fast

78Channels mode

CH	Function	DMX	Details
1	Red	0-255	Red dimmer
2	Red Fine	0-255	Red fine control
3	Green	0-255	Green dimmer
4	Green Fine	0-255	Green fine control
5	Blue	0-255	Blue dimmer
6	Blue Fine	0-255	Blue fine control
7	White	0-255	White dimmer
8	White Fine	0-255	White fine control
9	CTO	0-9	No function
		10-255	Linear CTO
10	Macro Color	0-255	Marco color
11	strobe	0-3	No function, Light off
		4-103	Strobe with the same step from slow to fast
		104-107	No function, light up
		108-207	Pulse strobe from slow to fast
		208-212	No function, light up
		213-251	Random strobe from slow to fast
		252-255	No function, light up
12	Dimmer	0-255	0-100 linear dimmer from dark to bright
13	Dimmer Fine	0-255	Dimmer fine control
14	Pan	0-255	Pan movement control
15	Pan Fine	0-255	Pan fine control
16	Tilt	0-255	Tilt movement control
17	Tilt Fine	0-255	Pan fine control
18	Function	0-255	Revered channel, no function at this moment
19	Reset	0-25	No function
		26-76	Effect reset
		77-127	Pan/Tilt reset
		128-255	All reset with 5 seconds
20	Zoom	0-255	Zoom
21	Zoom Rotation	0-127	0 to 60 degree
		128-190	Unlimited anticlockwise rotation from fast to slow
		191-192	Stop
		193-255	Unlimited clockwise rotation from slow to fast
22	Red dimmer 1	0-255	LED 1 red dimmer
23	Green dimmer 1	0-255	LED 1 green dimmer
24	Blue dimmer 1	0-255	LED 1 blue dimmer
25	Red dimmer 2	0-255	LED 2 red dimmer
26	Green dimmer 2	0-255	LED 2 green dimmer
27	Blue dimmer 2	0-255	LED 2 blue dimmer
.....
...
76	Red dimmer 19	0-255	LED 19 red dimmer
77	Green dimmer 19	0-255	LED 19 green dimmer
78	Blue dimmer 19	0-255	LED 19 blue dimmer

Channel	Function	DMX Value	Details
1	Red	0-255	Red dimmer
2	Red Fine	0-255	Red fine control
3	Green	0-255	Green dimmer
4	Green Fine	0-255	Green fine control
5	Blue	0-255	Blue dimmer
6	Blue Fine	0-255	Blue fine control
7	White	0-255	White dimmer
8	White Fine	0-255	White fine control
9	CTO	0-9	No function
		10-255	Linear CTO
10	Macro colour	0-255	Marco color control
11	strobe	0-3	No function, Light off
		4-103	Strobe with the same step from slow to fast
		104-107	No function, light up
		108-207	Pulse strobe from slow to fast
		208-212	No function, light up
		213-251	Random strobe from slow to fast
		252-255	No function, light up
12	Dimmer	0-255	0-100 linear dimmer from dark to bright
13	Dimmer Fine	0-255	Dimmer fine control
14	Pan	0-255	Pan movement control
15	Pan Fine	0-255	Pan fine control
16	Tilt	0-255	Tilt movement control
17	Tilt Fine	0-255	Pan fine control
18	Function	0-255	Reversed channel
19	Reset	0-25	No function
		26-76	Effect reset
		77-127	Pan/Tilt reset
		128-255	All reset with 5 seconds
20	Zoom	0-255	Zoom
21	Zoom Rotation	0-127	0 to 60 degree
		128-190	Unlimited anticlockwise rotation from fast to slow
		191-192	Stop
		193-255	Unlimited clockwise rotation from slow to fast
22	Red dimmer 1	0-255	LED 1 red dimmer
23	Green dimmer 1	0-255	LED 1 green dimmer
24	Blue dimmer 1	0-255	LED 1 blue dimmer
25	White dimmer 1	0-255	LED 1 white dimmer
.....
...
94	Red dimmer 19	0-255	LED 19 red dimmer
95	Green dimmer 19	0-255	LED 19 green dimmer
96	Blue dimmer 19	0-255	LED 19 blue dimmer
97	White dimmer 19	0-255	LED 19 white dimmer

8. Display instruction

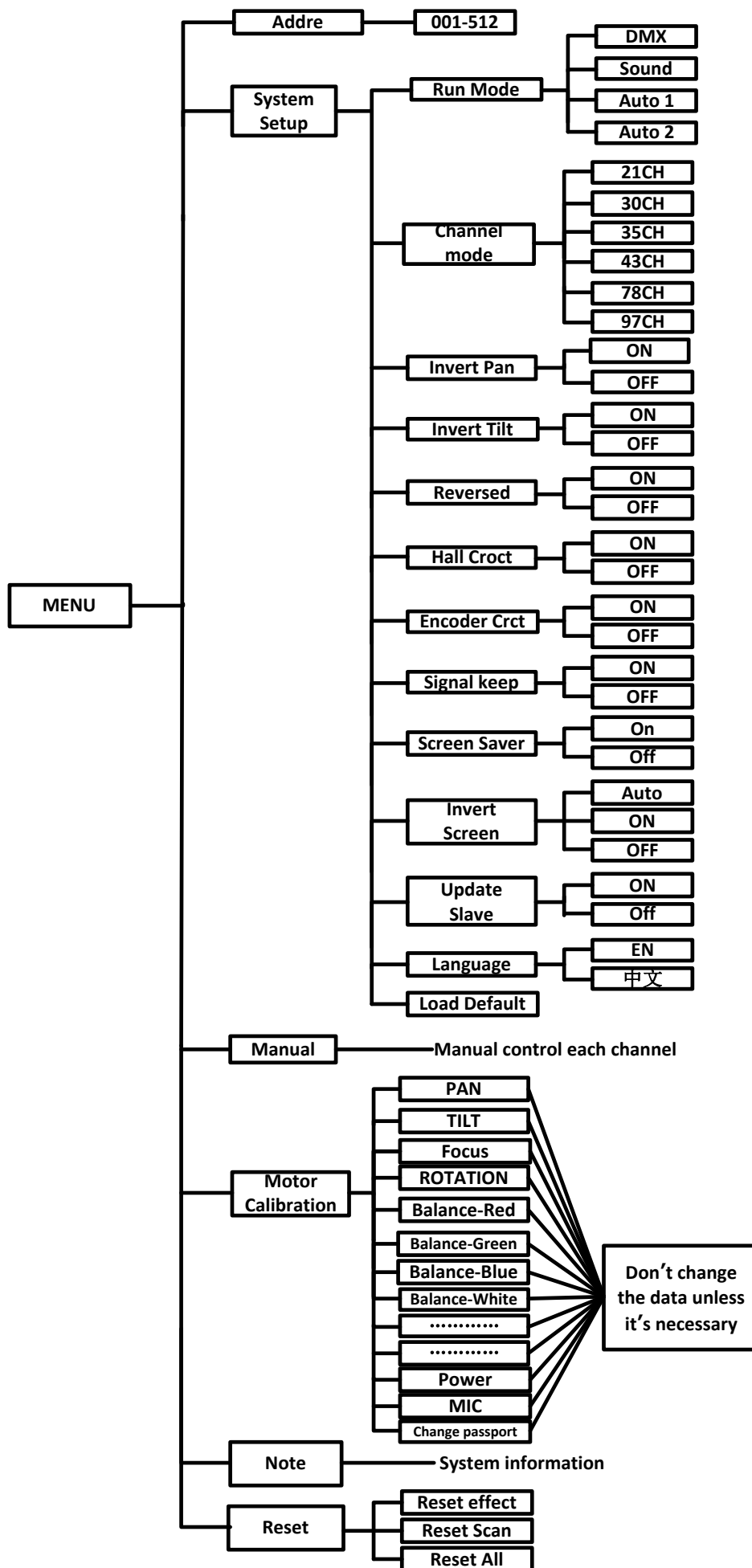

9. Photometric Data:

LUX Data of 7 degree beam angle:

R	8920 lux@3m	4300 lux@5m	2200 lux@7m	930 lux@10m
G	27300 lux@3m	9800 lux@5m	5700 lux@7m	2650 lux@10m
B	920 lux@3m	385 lux@5m	185 lux@7m	100 lux@10m
W	28500 lux@3m	10500 lux@5m	6000 lux@7m	2800 lux@10m
RGBW	60000 lux@3m	24600 lux@5m	11500 lux@7m	6200 lux@10m

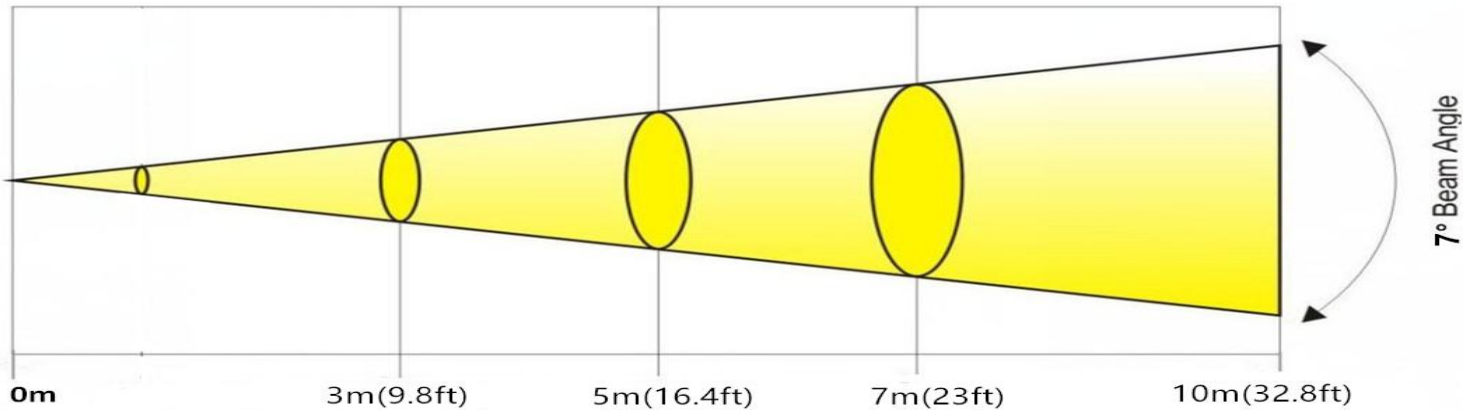

LUX Data of 60 degree beam angle:

R	520 lux@3m	210 lux@5m	105 lux@7m	70 lux@10m
G	1330 lux@3m	650 lux@5m	320 lux@7m	173 lux@10m
B	55 lux@3m	23 lux@5m	12 lux@7m	10 lux@10m
W	1300 lux@3m	630 lux@5m	310 lux@7m	170 lux@10m
RGBW	3050 lux@3m	1200 lux@5m	680 lux@7m	400 lux@10m

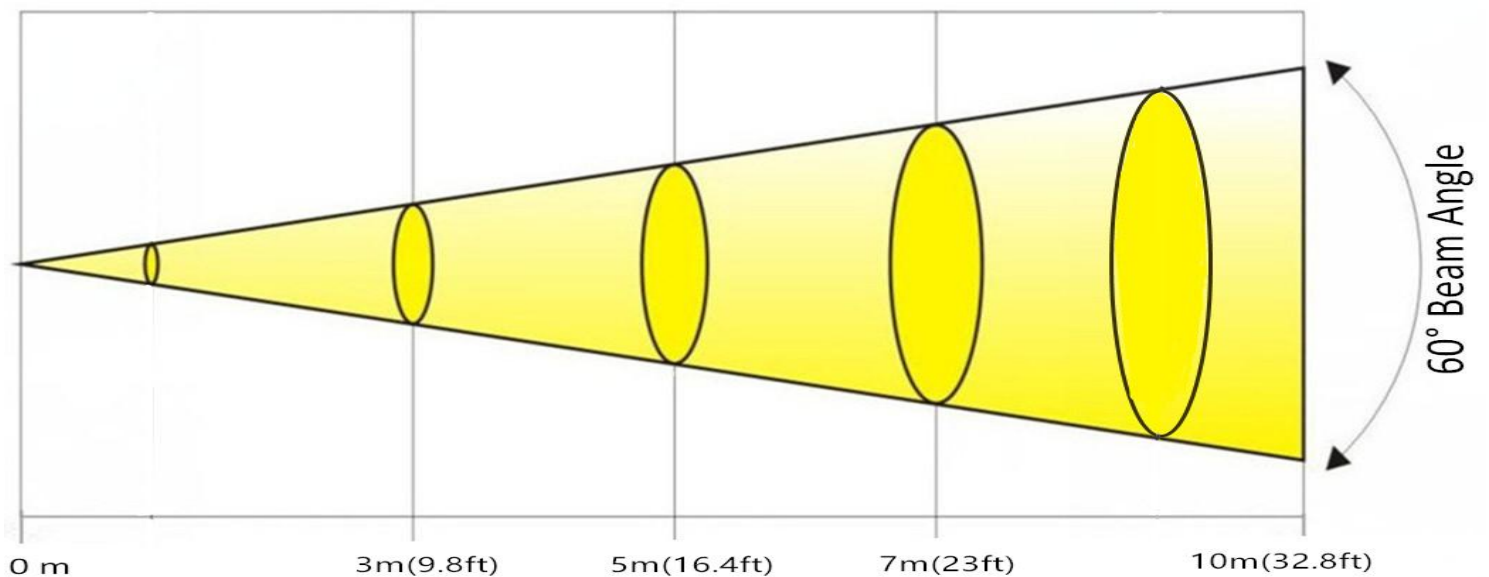

10. Key Features

Voltage: AC100V ~ 240V 50-60HZ

Rated Power: 760W

LED Source: 19x40W high power RGBW 4 in 1 LEDs

Zoom: 7°-60°

Strobe: 0-25Hz

Control Mode: DMX512, Sound-actived, Master/slave

DMX Channels: 21/30/35/43/78/97 six channel mode

Dimmer: 0-100% linear dimmer

Pan: 540°+16bit fine

Tilt: 220°+16bit fine

Display: LCD colorful display

IP: IP20

Fixture dimension: 405*234*440mm

N.W:15.2 Kg

G.W: 18.7 Kg

Package dimension: 62*39*51 CM (1pc/ctn)

Special Points.

1. Each LED can be controlled individually. With unique honeycomb designed lens
2. The front lens can rotate without limitation in forward and reverse direction to create amazing effects
3. Can be used as beam, wash or effect light use (Kaleido effects)
4. With a extra LED ring for eye-candy effect, LED ring with macro effect

11. Maintenance and Cleaning

The following points have to be considered during the inspection:

1. All screws for installing the devices or parts of the device have to be tightly connected and must not be corroded. 2. There must not be any deformations on the housing, color lenses, fixations and installation spots (ceiling, suspension, trussing). 3. Mechanically moved parts must not show any traces of wearing and must not rotate with unbalances. 4. The electric power supply cables must not show any damage, material fatigue or sediments.

Further instructions depending on the installation spot and usage have to be adhered by a skilled installer and any safety problems have to be removed.



CAUTION!

Disconnect from mains before starting maintenance operation.

In order to make the lights in good condition and extend the life time, we suggest a regular cleaning to the lights.

- 1) Clean the inside and outside lens each week to avoid the weakness of the lights due to accumulation of dust.
- 2) Clean the fan each week.
- 3) A detailed electric check by approved electrical engineer each three month, make sure that the circuit contacts are in good condition, prevent the poor contact of circuit from overheating.

We recommend a frequent cleaning of the device. Please use a moist, lint- free cloth. Never use alcohol or solvents. There are no serviceable parts inside the device. Please refer to the instructions under "Installation instructions". Should you need any spare parts, please order genuine parts from your local dealer