



**PRO  
LUX**



## **LED 1950 MAGIC**

Please keep reading this manual carefully for further use!

**USER MANUAL**

# CONTENTS

1. Safety Instructions.....	1
2. Technical Specifications .....	3
3. Drawing .....	4
4. Installation Instructions.....	5
5. DMX-512 Control Connection .....	6
6. Menu Description .....	7
7. Error Messages.....	12
8. DMX Channel Table & Description.....	13
9. Cleaning & Maintenance .....	20

## 1. SAFETY INSTRUCTIONS

### IMPORTANT SAFETY WARNINGS

This device has left the factory in perfect condition. In order to maintain this condition and to ensure safe operation, it is absolutely necessary for the user to follow the safety instructions and warning notes written in this user manual.

In order to install, operate and maintain the lighting fixture safely and correctly we suggest that the installation and operation be carried out by qualified technicians and these instructions be carefully followed.

Caution



High voltage. Risk of severe or fatal electric shock.



Always disconnect the main power supply before removing the cover of any fixture covers.



Never look directly into the light source. Sensitive persons may suffer an epileptic shock.



Blue light hazard: Risk Group 2



Never touch the device cover, as it may be hot during use.



This fixture is not designed for permanent use in a marine / corrosive environment. Following temporary use in such environments, clean fixture with fresh water and dry before storage.



Warning: Changes or modifications to this unit not expressly approved by the party responsible for compliance could void the user's authority to operate the equipment.

Note: This equipment has been tested and found to comply with the limits for a Class A digital device, pursuant to Part 15 of the FCC Rules. These limits are designed to provide reasonable protection against harmful interference when the equipment is operated in a commercial environment. This equipment generates, uses, and can radiate radio frequency energy and, if not installed and used in accordance with the instruction manual, may cause harmful interference to radio communications. Operation of this equipment in a residential area is likely to cause harmful interference, in which case the user will be required to correct the interference at their own expense.

Damage caused by the disregard of this user manual is not subject to warranty. The dealer and manufacturer will not accept liability for any resulting defects or problems.

- If the device is exposed to temperature changes due to environmental conditions, do not immediately power it on. The resulting condensation may damage the device. Keep the device powered off until it reaches room

temperature.

- Ensure the sealing rubber covers of powerCON and XLR connectors are fitted properly when the device is not in use to
- avoid water ingress.
- This device falls under protection-class I. Therefore, it is essential that the device be earthed.
- If either lenses or display are damaged (damage may include cracks or gashes in the material) they must be replaced.
- Electrical connections, such as replacing the power plug, must be performed by a qualified person.
- Make sure the available voltage is not higher than that specified in this manual.
- Make sure the power cable is not crushed or damaged by sharp edges. If this happens, the cable must be replaced by an authorized dealer.
- If the external flexible power cord of this device is damaged, it shall be exclusively replaced by the manufacturer or their service agent or a similar qualified person in order to avoid injury.
- When the device is not in use or before performing maintenance, always disconnect the device from the mains. Only handle the power cord from the plug. Never pull the plug out of a socket by tugging the power cord.
- When powered on for the first time, some smoke or smell may occur. This is caused by coating on metal parts when heated and is normal. If you are concerned, please contact your distributor.
- Do not focus the beam onto flammable surfaces. The minimum distance between the device's exit lens and the illuminated surface must be greater than 0.5 meters.

**Please be aware that damage caused by any modifications to the device are not subject to warranty. Keep away from children and non-professionals.**

## **GUIDELINES**

This device is a professional lighting effects device used in stages, discos, theaters, etc. This device is designed for indoor use.

This device is intended for operation only within the maximum AC power range specified in Section 2, Technical Specifications of this manual.

- When installing or maintaining the device, please handle the device with care and avoid shaking or applying force.
- If you use the quick lock cam when rigging the device, make sure the quick lock fasteners are located in the quick lock holes correctly and securely.
- Operate the device only after having familiarized yourself with its functions. Do not permit operation by persons not qualified for operating the device. Most damage is the result of unprofessional operation..
- If you need to transport the device, please use the original packaging.
- The operating temperature range of the device is -18°C to 45°C. Do not use the device outside this temperature range.
- The light source contained in this luminaire shall only be replaced by the manufacturer or his service agent or a similar qualified person.

**For safety reasons, please note that all modifications to the device are prohibited. If you operate this device in any manner different from that described in this manual, the product may be damaged and the warranty will be void. In addition, any other operation may result in a short circuit, burns, electric shock, and other dangerous situations.**

## **2. TECHNICAL SPECIFICATIONS**

### **POWER SUPPLY**

- Input Voltage: AC 100 ~ 240V, 50/60Hz
- Power Consumption: 950 W maximum

### **OPTICS**

- Beam Angle: 6° to 55°

### **LIGHT SOURCE:**

- LED lamp: 19x50W RGBL 4in1 LED
- Backlight LED: 210PCS RGB 3in1 LED
- Extremely long life: < 40,000H
- Movement
- Pan movement: 540° (16bit)
- Tilt movement: 270° (16bit)
- Advanced moving system: fast, stable and quite, auto X-Y repositioning

### **COLOR**

- Advanced 4-color RGB-S mixing technology with high color rendering index and wide color temperature range of 2400-10000K. Uniform light beam with no colour shadows, and rich saturated and pastel colour-hues. Supports 4.29 billion colors (8-bit resolution)
- Virtual color wheel, including the most commonly used white color temperature presets

### **EFFECTS**

- 2D & 3D graphical effects capabilities
- Effects can be coupled with beam, wash or matrix applications
- Built-in pattern effects with speed and fade controls, suitable for scene applications
- Individual control of each pixels
- LiquidEffect™

### **DIMMER/STROBE**

- Electronic dimmer from 0 to 100%
- Strobe effect: 1 to 20 flashes per second

### **HARDWARE FEATURES**

- Graphic LCD display with flip function
- 4 menu buttons to set functions
- P65 XLR 3-pin connector

- IP65 etherCON RJ45 connectors
- IP65 powerCON TRUE1 connector

### **CONTROL**

- DMX 512 protocol.
- DMX-RDM compatible
- Stand-alone mode, local control panel
- ArtNet™ & sACN protocol
- 4 DMX modes: 26/50/50/127 channels

### **COOLING SYSTEM**

- Advanced liquid cooling system
- Selectable ventilation user modes
- Excess temperature protection

### **HOUSING**

- Skeleton made of magnesium-aluminum alloy metal plates
- Base in die-cast composite alloy
- Heatsinks in aluminium
- Molded housing
- 2-side handles for transportation
- 4 heavy-duty feet for better stability
- IP66 protection rating

### **INSTALLATION**

- 2 Omega ¼ turn brackets
- 4 ¼ turn mounting points
- Safety cable attachment point

### **OPERATION PARAMETERS**

- Maximum permitted: 45°C (113°F)
- Minimum permitted: -18°C (-4°F)
- Minimum usage distance: 2 m (6.56 ft)

### **COMPLIANCE**

- CE Certification

### **SIZE**

- Product: 349 x 216.5x 350mm

### **WEIGHT**

- Net weight: 17kg

## **3. DRAWING**

### **FIXTURE DIMENSION**

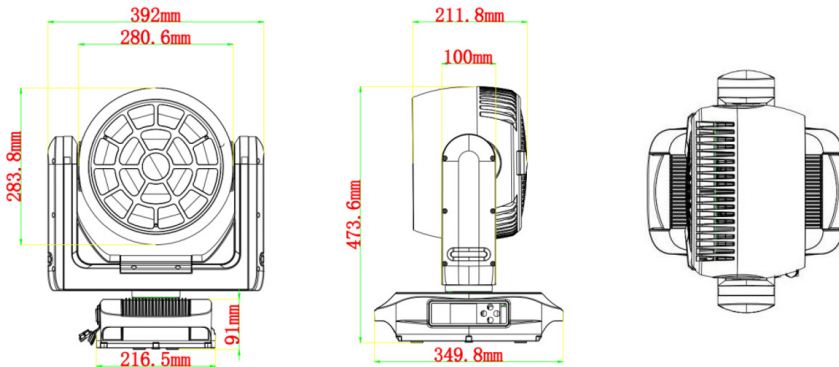

## 4. INSTALLATION INSTRUCTIONS

### RIGGING THE DEVICE

**Please consider the respective national norms during the installation. The installation must only be carried out by a qualified person.**

- The installation of the support structure has to be built and constructed in a way that it can hold 10 times the weight for 1 hour without any harming deformation.
- The installation must always be secured with a secondary safety attachment, e.g. an appropriate safety rope. Never stand directly below the device when mounting, removing or servicing the fixture.
- The operator has to make sure the safety relating and machine technical installations are approved by an expert before taking the device into operation for the first time.
- These installations have to be approved by a skilled person once a year.
- Overhead mounting requires extensive experience, including amongst others calculating working load limits, installation material being used, and periodic safety inspection of all installation material and the device. If you lack these qualifications, do not attempt the installation yourself. Improper installation can result in bodily injury.

## RIGGING USING THE OMEGA BRACKETS

**This step is very important to ensure safe rigging of the fixture.**

- Fix the clamp to the bracket by tightening the M12 nut and bolt to the bracket through the  $\Phi 13$  hole in the middle of the bracket.
- Insert the quick-lock fasteners of the first Omega holder into the respective holes on the bottom of the device. Tighten the quick lock fasteners fully clockwise.
- Install the second Omega holder.
- Pull the safety cable through the holes on the bottom of the base and over the trussing system or another suitable rigging point. Insert the end into the carabiner and tighten the safety screw.

## RIGGING INSTALLATION

### Caution

**Overhead rigging requires extensive experience, including (but not limited to) calculating working load limits, specifying installation/ rigging materials, and periodic safety inspection of all installation material as well as the device. If you lack these qualifications, do not attempt the rigging of this device yourself. Improper installation/ rigging can result in serious bodily injury.**

- Be sure this fixture is kept at least 0.1 m away from any flammable materials (decoration etc.).
- Always use and install a safety cable as a safety measure to prevent accidental damage and/or injury in the event the clamp fails.
- Rig the projector high enough to provide clearance for people who may walk beneath the beam path or establishing a restricted access area that extends beyond the beam hazard distance.

**WARNING! Please DO NOT let other external intense lights to shine through the fixture front lens, it may cause significant internal damages!**

- When install fixture outdoor at day time (with power off), please make sure that the fixture front lens is NOT facing the sun.
- When use fixture outdoor at day time (with power on), please avoid fixture front lens facing the sun.
- When fixture is on standby outdoor at day time (with power ON and no DMX signal), please make sure the “sun protection” mode is ON (default).

## 5. DMX-512 CONTROL CONNECTION

Connect the provided male side of the XLR cable to the female XLR output of your controller and the female side of the XLR cable to the male XLR input of the device. You can connect multiple devices together in a serial fashion. The cable needed should be two core, screened cable with XLR input and output connectors. Please refer to the diagram below.

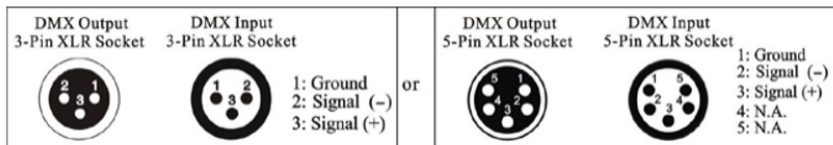

### DMX-512 CONNECTION WITH DMX TERMINAL

For installations where the DMX cable has to run over a long distance or is in an electrically noisy environment, such as in a discotheque, it is recommended to use a DMX terminator. This helps in preventing corruption of the digital control signal caused by electrical noise. The DMX terminator is an

XLR plug with a 120  $\Omega$  resistor connected between pins 2 and 3, which is then plugged into the output (female) XLR socket of the last fixture in the chain. Please see illustrations below.

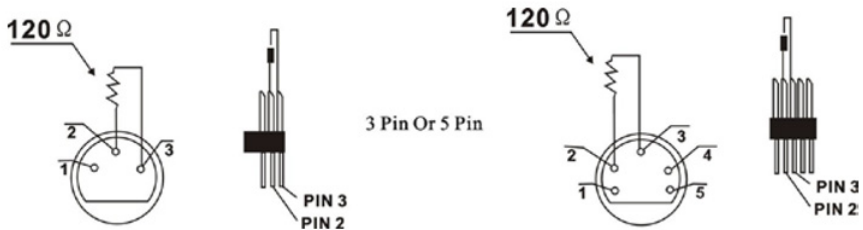

### **DEVICE DMX START ADDRESS SELECTION**

All fixtures should be given a DMX starting address when using a DMX signal, so that the correct fixture responds to the correct control signals. This digital starting address is the channel number from which the fixture starts to “listen” to the digital control information sent out from the DMX controller. The allocation of this starting address is achieved by setting the correct address number on the display located on the base of the device.

You can set the same starting address for all fixtures or a group of fixtures, or set different addresses for each fixture individually.

If you set the same address on all devices, all the devices will start to “listen to” the same control signal from the same channel number. In other words, changing the settings of one channel will affect all the fixtures simultaneously.

If you set a different address, each unit will start to “listen to” the channel number you have set, based on the quantity of control channels of the unit. That means changing the settings of one channel will affect only the selected device.

In the case of the LED moving head, in 50 channel mode, you should set the starting address of the

first unit to 1, the second unit to 51(50 + 1), the third unit to 101 (50 + 51), and so on.

## 6. MENU DESCRIPTION

Press the MENU button to enter the menu. Confirm the selected function with the ENTER button. Use the UP/DOWN buttons to select a mode. Once a mode is selected, press the ENTER button to confirm. To return to the main menu, press the MENU button. If no button is pressed for 15 seconds, the menu function will automatically exit.

System Setting				Description
DMX Address	1-512			DMX address setting
LED DMX Address	1-512			LED DMX address
DMX Channel Mode	26CH			DMX channel mode selection
	50CH1			
	50CH2			
	127CH			
Operation Mode	DMX			DMX512
	Artnet			Artnet
	Artnet + DMX			Artnet + DMX512
	Effect 1			Auto mode1
	Effect 2			Auto mode2

Network Setting	DHCH	Off/On		DHCP	
	IP Setting	IP address	xxx. xxx. xxx. xxx	IP address setting	
		Sub-Net Mask		255. 000. 000. 000	Sub-Net mask
				255. 255. 000. 000	
		255. 255. 255. 000			
	Artnet Setting	Network	0-127		
		Sub-Net	0-15		
		Data packet	0-15		
	sACN Setting	Data Packet	1-32000		
		Priority	0-200		
	Protocol selection	Auto			
		Artnet			
sACN					
Pan Reverse	No/Yes			Pan Reverse movement	
Tilt Reverse	No/Yes			Tilt Reverse movement	
Encoder Calibration	No/Yes			Calibrate and adjust the effects to standard/ right position	
Fan Mode	Auto			Fan mode selection	
	Low speed				
	High speed				
Signal Hold	Clear/Hold			Signal hold selection	
Dimmer	Slow/Fast			Dimmer speed selection	

Dimmer Curve	Linear			Dimmer Curve
	Square Law			
	Inverse Square Law			
	S-Curve			
Dimmer Frequency	1.2kHz			Dimmer frequency
	2.4kHz			
	16kHz			
	20kHz			
Flip Display	Off/On			Screen flip
Backlight Control	Off/On			Backlight control
Auto Key Lock	Off/On			Auto key lock
Language Selection	Chinese/ English			Language selection
Temperature	C/F			Temp Unit (C/F)
Reset Default	Off/On			Restore factory set
Manual Control				
Control	26CH			Channel-Based display
	50CH1			
	50CH2			
	127CH			
White Balance Setting				
Red	0-255			
Green	0-255			
Blue	0-255			
White	0-255			
System Test				
Effect 1				Test effect
Effect 2				
System Reset				
All	No/Yes			Reset All
Pan&Tilt	No/Yes			Reset Pan&Tilt
Zoom	No/Yes			Reset Zoom

System Information				
Software Ver	Display:	Vxx.xx		Display version
	Motor:	Vxx.xx		Motor version
	LED board:	Vxx.xx		LED board version
RDM Info	OXxxxxxxxxxxxx			RDM UID
Humidity	x%			Humidity
Temp. Info	LED	xx C/xx F		LED board temperature
	Base	xx C/xx F		Base temperature
Channel Test				DMX channel value testing
Error Info				Error Info display

## 6.1 SYSTEM SETTING

### DMX ADDRESS

Select the DMX address, press the ENTER button to confirm, use the UP/DOWN button to adjust the address 1-512, press the ENTER button to setup.

### LED DMX ADDRESS

Select the LED DMX address, press the ENTER button to confirm, use the UP/DOWN button to adjust the address 1-512, press the ENTER button to setup.

### DMX CHANNEL MODE

With this function, you can select the DMX channel mode you need.

### OPERATION MODE

With this function, you can select the operation mode you need.

(When you need to use auxiliary lighting effects to connect to sACN or Artnet, please adjust the mode to Artnet+DMX mode).

## **NETWORK SETTING**

- DHCP

This function allows you to enable or disable the DHCP.

- IP Setting

This function allows you to set the IP and the IP Sub-Net Mask of the Unit.

- Artnet Setting

This function allows you to set the Network, Sub-Net and data packets that receive Artnet.

- sACN Setting

This function allows you to set the data packets and priority for receiving sACN.

- Protocol Selection

This function allows you to select the protocol from Auto, Artnet, sACN.

## **PAN REVERSE**

With this function you can reverse the Pan-movement.

## **TILT REVERSE**

With this function, you can reverse the Tilt-movement.

## **ENCODER CALIBRATION**

Using this function, the encoder will automatically correct.

## **FAN MODE**

Auto: The fan rises and falls according to the ambient temperature and the temperature of the LED module itself.

Low speed: When the light dimming is on, the fan speed is stable at low speed.

High speed: Fans maintain full speed when light dimming is on.

## **SIGNAL HOLD**

When this function is turned on, you can use the manual control settings in the menu when there is no external signal. When there is an external signal, the state when the signal is interrupted will be maintained after the signal is interrupted.

## **DIMMER**

With this function, you can select slow/fast dimmer speed.

## **DIMMER CURVE**

With this function, you can select dimmer curve.

### **Dimmer Modes**

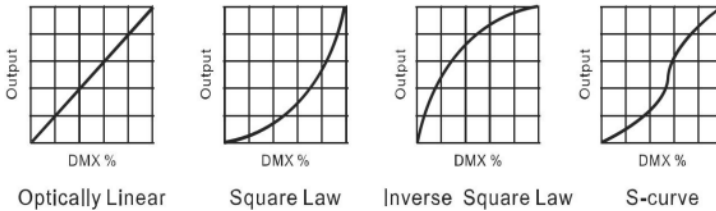

## **DIMMER FREQUENCY**

With this function, you can select the frequency of dimmer output.

## **FLIP DISPLAY**

With this function, you can flip the display 180°.

## **BACKLIGHT CONTROL**

With this function, the display backlight turns off one minute after exiting the menu mode.

## **AUTO KEY LOCK**

Using this function, the display will lock itself when it turns back on—just press a specific key to unlock it.

## **LANGUAGE SELECTION**

With this function, the display control will show Chinese/English.

## **TEMPERATURE**

With this function, you can select C/F.

## **RESET DEFAULT**

With this function, you can select restore factory set for ON or OFF. The default is OFF.

## **MANUAL CONTROL**

With this function, you can select a defined channel value to set.

## **WHITE BALANCE SETTING**

1. Red

With this function, you can set the output value of red, the default value is 255.

2. Green

With this function,you can set the output value of green, the default value is 255.

### 3. Blue

With this function,you can set the output value of blue, the default value is 255.

### 4. White

With this function,you can set the output value of white, the default value is 255.

## **SYSTEM TEST**

You can perform an auto-run test using Effect 1 and Effect 2, and check the integrity of the device functions through the auto-run process.

## **SYSTEM RESET**

### 1. Reset All

With this function,the light will run the built-in program to reset all.

### 2. Reset Pan&Tilt

With this function,the light will run the built-in program to reset Pan&Tilt.

### 3. Reset Zoom

With this function,the light will run the built-in program to reset zoom.

## **SYSTEM INFORMATION**

### 1. Software Ver

With this function,you can display the software versions of all components connected to the display panel in the device.

- Display: Display version
- Motor: Motor version
- LED board: LED board version

### 2. RDM Info

With this function,you can display the RDM UID in the device.

### 3. Humidity

With this function,you can display the humidity value in the device.

### 4. Temp. Info

With this function,you can display all the different temperature values available in the device.

- LED: LED board temperature.

- Base: Base temperature

## 5. Channel Test

With this function, you can display the DMX 512 values of the number of channels starting from the current address. The display will automatically show the channels where the values change.

## 6. Error Info

With this function, you can read the current error logs.

# 7. ERROR MESSAGES

When the device is started, the light will perform a reset. If there is an issue with one or more functions, the message “System Fault” will be displayed on the home screen of the display.

## **MOTOR BOARD COMMUNICATION ERROR**

When the light’s wires are loose or broken, this error will occur.

## **LED BOARD COMMUNICATION ERROR**

When the light’s wires are loose or broken, this error will occur.

## **X-AXIS HALL ERROR**

When the X-axis Hall module of the light is damaged,or the module’s connecting socket is loose or has a broken wire.or has a broken wire,this error will occur.

## **Y-AXIS HALL ERROR**

When the Y-axis Hall module of the light is damaged,or the module’s connecting socket is loose or has a broken wire,this error will occur.

## **X OPTOCOUPLER ERROR**

When the X-axis optocoupler module of the light is damaged,or the module’s connecting socket is loose or has a broken wire.or has a broken wire,this error will occur.

## **X OPTOCOUPLER ERROR**

When the Y-axis optocoupler module of the light is damaged,or the module’s connecting socket is loose or has a broken wire.or has a broken wire,this error

will occur.

### **TEMPERATURE ERROR**

When the temperature module is damaged, this error will occur.

## **8. DMX CHANNEL TABLE & DESCRIPTION**

Channel Mode				Function Description	DMX Value
26 CH	50 CH - 1	50 CH - 2	127 CH		
1	1	1	1	Pan 8bit	0-255
2	2	2	2	Pan Fine 16bit: Fine control pan-movement	0-255
3	3	3	3	Tilt 8bit	0-255
4	4	4	4	Tilt Fine 16bit: Fine control tilt-movement	0-255
5	5	5	5	Pan&Tilt Speed: Maximum to minimum	0-255
6	6	6	6	Reserved	0-255
7	7	7	7	Reserved	0-255
8	8	8	8	Red - Main light / Control backlight when effect is on red (0-black, 255-100% red)	0-255
9	9	9	9	Red Fine- Main light / Control backlight when effect is on red fine-tuning(0-black, 255-100% red)	0-255
10	10	10	10	Green - Main light / Control backlight when effect is on green (0-black, 255-100% green)	0-255
11	11	11	11	Green Fine - Main light / Control backlight when effect is on green fine-tuning(0-black, 255-100% green)	0-255

12	12	12	12	Blue - Main light / Control backlight when effect is on blue(O-black, 255-100% blue)	0-255	
13	13	13	13	Blue Fine - Main light / Control backlight when effect is on blue fine-tuning(O-black, 255-100% blue)	0-255	
14	14	14	14	White - Main light / Control backlight when effect is on white (O-black, 255-100% white)	0-255	
15	15	15	15	White Fine - Main light / Control backlight when effect is on white fine-tuning(O-black, 255-100% white)	0-255	
16	16	16	16	Strobe	OFF	0-31
					ON	32-63
					Slow to fast	64-95
					ON	96-127
					Strobe Pulse (slow to fast)	128-159
					ON	160-191
					Random Strobe (slow to fast)	192-223
					ON	224-255
17	17	17	17	Dimmer: intensity 0 to 100%	0-255	
18	18	18	18	Dimmer Fine	0-255	
19	19	19	19	Color Temperature	No function	0-21
					10000K	22-31
					9600K	32-41
					9200K	42-51
					8800K	52-61

19	19	19	19	Color Temperature	8400K	62-71
					8000K	72-81
					7600K	82-91
					7200K	92-101
					6800K	102-111
					6400K	112-121
					6000K	122-131
					5600K	132-141
					5200K	142-151
					4800K	152-161
					4600K	162-171
					4200K	172-181
					3800K	182-191
					3600K	192-201
					3400K	202-211
					3200K	212-221
					3000K	222-231
2800K	232-241					
2600K	242-251					
2500K	252-255					
20	20	20	20	Color Preset: base on the color preset table	0-206	
21	21	21	21	Color Presets & Main Light Color RGBW Crossfade	Output main light color RGBW	0
					Crossfade output	1-254
					Output preset color	255
22	22	22	22	Crossfade Between Color Presets	No Fade	0-4
					Crossfade between two preset colors	4-255

					100ms to 5s	
23	23	23	23	Zoom : narrow to wide		0-255
24	24	24	24	Zoom Fine		0-255
25	25	25	25	Reserved		0-255
26	26	26	26	Macro Function	No function	0-4
					Display-Off	5-9
					Display-On	10-14
					Display invert-Off	15-19
					Display invert-On	20-24
					Fan control - Auto	25-26
					Fan control-High speed	27-28
					Fan Control-Low speed	29-30
					Reserved	31-32
					Reserved	33-34
					Reserved	35-36
					Reserved	37-44
					Dimmer curve -Square	45-49
					Dimmer curve - Linear	50-54
1.2K	55-57					
2.4K	58-60					
16K	61-63					
25K	64-69					

26	26	26	26	Macro Function	Dimmer Curve - Inverse Square Law	70-71
					Dimmer curve-S curve	72-73
					Dimming mode - slow	74-75
					Dimming Mode - Fast	76-77
					Reserved	78-79
					Reset All	80-84
					Reset Pan&Tilt	85-87
					Reset Zoom	88-90
					Reserved	91-255
					Effect OFF	0-9
					Effect 1	10-15
					Effect 2	16-23
					Effect 3	24-31
					Effect 4	32-39
					Effect 5	40-47
					Effect 6	48-55
					Effect 7	56-63
					Effect 8	64-71
					Effect 9	72-79
					Effect 10	80-87
					Effect 11	88-95
					Effect 12	96-103
					Effect 13	104-111
					Effect 14	112-119
					Effect 15	120-127
					Effect 16	128-135
Effect 17	136-143					

27	27	27	Main Light Pattern Effect	Effect 18	144-151
				Effect 19	152-159
				Effect 20	160-167
				Effect 21	168-175
				Effect 22	176-183
				Effect 23	184-191
				Effect 24	192-199
				Effect 25	200-207
				Effect 26	208-215
				Effect 27	216-223
				Effect 28	224-231
				Effect 29	232-239
Effect 30	240-247				
Effect 31	248-255				
28	28	28	Main Light Pattern Effect Speed	Reverse fast to slow	0-125
				Stop (speed=0)	126-130
				Forward slow to fast	131-255
29	29	29	Main Light Pattern Fade: Fade Chase	0-255	
30	30	30	Main Light Pattern Size: Chase category	0-255	
31	31	31	Pattern Effect - Red: red (0-black , 255-100% red)	0-255	
32	32	32	Pattern Effect - Green: green (0-black , 255-100% green)	0-255	
33	33	33	Pattern Effect - Blue: blue (0-black , 255-100% blue)	0-255	

	34	34	34	Pattern Effect - White: white (0-black , 255-100% white)	0-255	
	35	35	35	Pattern Effect Dimmer: Intensity (0-black, 255- 100%)	0-255	
	36	36	36	Pattern Effect Backlight Dimmer: Inactive when effect is Off Intensity (0-100%, 255-0%)	0-255	
	37	37	37	Pattern Effect Strobe	OFF	0-31
				ON	32-63	
				Strobe slow to fast	64-95	
				ON	96-127	
				Strobe Pulse (slow to fast)	128-159	
				ON	160-191	
				Random Strobe (slow to fast)	192-223	
				ON	224- 255	
	38		38	Auxiliary Light Effect Control	Auxiliary light channel control effect	0-9
				Follow main light	10-19	
				ARTNET or SACN control	20-29	
				Reserved	30-255	
	39		39	Auxiliary Light Effect Dimming: Intensity 0 to 100%	0-255	
	40		40	Auxiliary Light Effect Dimming Fine-Tuning	0-255	

41		41	Auxiliary Light Effect -Red: red (O-black, 255-100% red)		0-255
42		42	Auxiliary Light Effect -Green: green (O-black, 255-100% green)		0-255
43		43	Auxiliary Light Effect -Blue: blue (O-black, 255- 100% blue)		0-255
44		44	Auxiliary Light Effect	Effect Off	0-9
				Effect1	10
				Effect 2	11-12
				...	...
				Effect 122	253- 254
				Effect 123	255
45		45	Reserved	Reserved	0-255
46		46	Auxiliary Light Effect Speed	Reverse fast to slow	0-125
				Stop (speed=0)	126-130
				Forward slow to fast	131-255
47		47	Auxiliary Light Effect Backlight Dimmer: Intensity 0 to 100%		0-255
48		48	Auxiliary Light Effect Backlight -Red: red (O-black, 255-100% red)		0-255
49		49	Auxiliary Light Effect Backlight -Green: green (O-black, 255-100% green)		0-255
50		50	Auxiliary Light Effect Backlight -Blue: blue (O-black, 255-100% blue)		0-255

		38	51	Point-controlled Crossfade: main light RGBW and point-controlled crossfade output Point Control	0-255
		39		Ring 1 Red: Red (0-black , 255-100% red)	0-255
		40		Ring 1 Green: Green (0-black , 255-100% green)	0-255
		41		Ring 1 Blue: Blue (0-black , 255-100% blue)	0-255
		42		Ring 1 White: White (0-black , 255-100% white)	0-255
		43		Ring 2 Red: Red (0-black , 255-100% red)	0-255
		44		Ring 2 Green: Green (0-black , 255-100% green)	0-255
		45		Ring 2 Blue: Blue (0-black , 255-100% blue)	0-255
		46		Ring 2 White: White (0-black , 255-100% white)	0-255
		47		Ring 3 Red: Red (0-black , 255-100% red)	0-255
		48		Ring 3 Green: Green (0-black , 255-100% green)	0-255
		49		Ring 3 Blue: Blue (0-black , 255-100% blue)	0-255
		50		Ring 2 White: White (0-black , 255-100% white)	0-255
			52	Red 1: Red (0-black , 255- 100% red)	0-255
			53	Green 1: Green (0-black , 255-100% green)	0-255
			54	Blue 1: Blue (0-black , 255- 100% blue)	0-255
			55	White 1: White (0-black , 255-100% white)	0-255
			56	Red 2: Red (0-black , 255- 100% red)	0-255
			57	Green 2: Green (0-black , 255-100% green)	0-255

		58	Blue 2: Blue (O-black , 255-100% blue)	0-255
		59	White 2: White (O-black , 255-100% white)	0-255
		...	...	...
		124	Red 19: Red (O-black , 255-100% red))	0-255
		125	Green 19: Green (O-black , 255-100% green)	0-255
		126	Blue 19: Blue (O-black , 255-100% blue)	0-255
		127	White 19: White (O-black , 255-100% white)	0-255

## 9. CLEANING & MAINTENANCE

### Caution



Disconnect from mains before starting maintenance operation



Do not place the fixture with its lens/glass facing any people while doing the IP test!



Never use alcohol or solvent to clean the lenses.



The operator must follow strictly the vacuum and pressure setting values as below, or use the corresponding preset fixture menu to run the IP test. any overpressure operation may cause accidental damage or injury.

	Minimum value		Maximum value		Steady time (Hold time)
	Kpa	Psi	Kpa	Psi	
Vacuum	-13	-5.08	-17	5.80	10
Pressure	13	3.63	17	4.35	10

To ensure that the cover is pressed evenly all around the seal, we recommend following the attached tightening order.

- Check the seal, it must be clean and undamaged, properly seated to avoid any damage when tightening.
- First lightly tighten the screws into position and then tighten with a torque screwdriver.

Torque value : 14Kgf.cm for metal cover or 7Kgf.cm for plastic cover.

The following points have to be considered during inspection:

- All screws for installing the devices or parts of the device have to be tightly connected and must not be corroded.
- All external magnesium alloy covers screws must be used together with the plastic sleeves. If the plastic sleeve is damaged, it must be replaced with a new one.
- Do not do maintenance or assembly for the external magnesium alloy cover in outdoor environment with rain or water on it. Before removing the screws, ensure that the surroundings of the screws are dry. After maintenance, before assembling the covers, ensure that the screws and screw holds are dry.
- There must not be any deformations to the housing, lenses, rigging and installation points (ceiling, suspension, trussing).
- Motorized parts must not show any signs of wear and must move smoothly without issue.
- The power supply cables must not show any damage, material fatigue or sediment.

Checking and replacing the desiccant:

The desiccant is used as humidity indication in the fixture. Dry desiccant is in blue colour, if it is saturated with water, its colour changes to light red. If the desiccant colour changes to pink, the

desiccant is losing efficacy, it must be replaced.

**Unplug the fixture from mains before checking or replacing desiccant! Do not check or replace desiccant in a damp environment!**

Further instructions depending on the installation location and usage have to be adhered to by a qualified installer and any safety concerns have to be removed.

In order to ensure the fixture remains in good condition and does not fail prematurely thus extend the lifespan of the fixture, we suggest regular maintenance and cleaning, especially when the fixture being installed outdoors with the following conditions which may easily cause peeling or corrosion of the surface coating of the fixture:

- Use in coastal or high salinity areas.
- Use in areas contaminated with coal ash, oil fume, mineral dust, iron powder, or chemical substances, etc..
- Fixture surface accumulated with burnt tar, resin, insect dead body or its droppings, bird droppings, etc..
- Liquids such as benzene, gasoline or diesel was splashed onto the surface of the fixture.
- Residues of movable props such as colored powder, foam and sequins on the surface.

Notes for cleaning:

- Before cleaning the fixture, please ensure that the power connection of the fixture is disconnected and completely cooled. Use sponge or a soft cloths for surface cleaning.
- Do not use acidic, alkaline or abrasive detergents for cleaning.
- Do not use a hard brush to brush the covers directly.
- When using a high-pressure water gun for cleaning, please pay attention to the water

pressure and spraying distance.

- Do not allow the high-pressure water gun to continuously wash the same area for long time, especially on the XLR connectors, display button, arm rotation areas, etc..
- If the fixture being used outdoors, cleaning and maintenance should be carried out at least every 3 months depending on the using conditions. This period may need to be shortened and need to be cleaned timely if the fixture being used in coastal or high salinity areas.
- During winter use, if using snow remover in the scene, please protect the fixture to avoid fixture surface being contaminated.
- During cleaning and maintenance, if slight coating damage is found on the die-casting cover's surface, then after cleaning is completed and surface is dried, repair for the surface treatment can be carried out by using hand spray paint. If the cover's damaged surface is severe, please contact your local dealer for replacement parts in a timely manner.
- If obvious corrosion marks such as blistering or damage are found on the coating of the fixture's die-casting cover, please contact your local dealer for replacement parts for repair in a timely manner.

We recommend frequent cleaning of the device.

Please use a moist, lint- free cloth. Never use alcohol or solvents.

Please refer to the instructions under "Installation instructions".

Should you need any spare parts, please order genuine parts from your local dealer.