



**PRO
LUX**



MOVING WASH



Please keep reading this manual carefully for further use!

USER MANUAL

TABLE OF CONTENT

- Dimension..... 3
- Safety Information..... 3
- Preparing for installation5
- Installation..... 6
- Connecting AC Power..... 6
- Configuring the fixture.....7
- Connecting to a DMX control device..... 8
- Configuring the fixture for DMX control 9
- Cleaning10
- DMX protocols11
- Control menu12
- Specification14
- Photometrics15

STATEMENT

The product has well capability and intact packing when leave factory. All of the user should comply with warning item and manual, any misuse cause of the damages are not included in our guarantee, and also can not be responsible for any malfunction & problem owing to ignore the manual.

1. DIMENSIONS

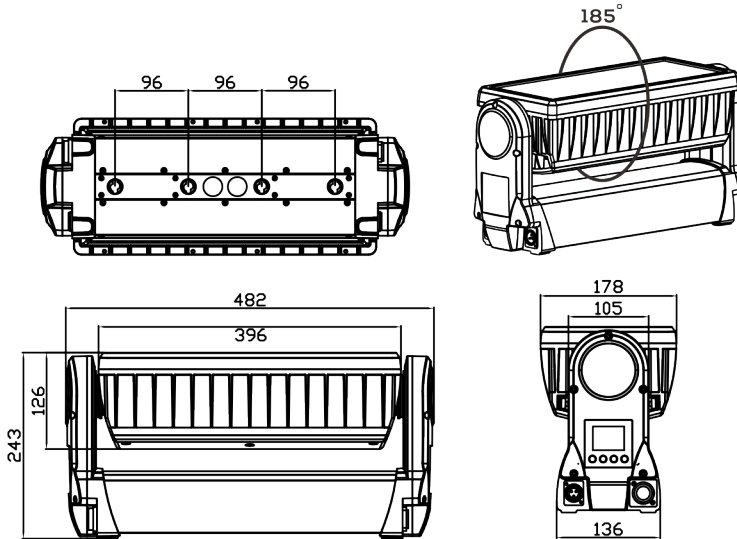

2. SAFETY INFORMATION



WARNING! Read the safety precautions in this section before unpacking, installing, powering or operating this product.

This luminaires are multi-environmental fixtures with an IP-rating of 65, intended for professional use only. They are not suitable for household use.

Review the following safety precautions carefully before installing or operating the fixture. This fixture must be installed in accordance with the applicable installation code by a person familiar with the construction and operation of the fixture and the hazards involved.

PREVENTING ELECTRIC SHOCK



WARNING! Risk of electric shock.

- Always power off/unplug the fixture before removing any covers.
- Ensure that the power is turned off when connecting the fixture to the AC mains supply.
- Ensure that the fixture is electrically connected to earth (ground).
- Do not apply power if the fixture is in any way damaged.
- Do not immerse the fixture in water or liquid.

PREVENTING BURNS AND FIRE



WARNING! Take measures to prevent burns and fire.

- Install in a location that prevents accidental contact with the fixture.
- Install only in a well-ventilated space.
- Install at least 0.3 m (12 in.) away from objects to be illuminated.
- Install only in accordance with applicable building codes.
- Ensure a minimum clearance of 0.1 m (4 in.) around the cooling fans.
- Do not paint, cover or modify the fixture.
- Keep all flammable materials away from the fixture.
- Allow the fixture to cool for 15 minutes after operation, before touching it.
- CAUTION: Exterior surface temperature after 5 min. operation = 45 °C (113 °F). Steady state = 60 °C (140 °F).

AVOID PERSONAL INJURY



WARNING! Take measure to prevent personal injury.

- Do not look directly at the light source from close range.
- Take precautions to prevent injury due to falls when working at height.
- For permanent installation, ensure that the fixture is securely fastened to a load-bearing surface with suitable corrosion-resistant hardware.
- For temporary installation with clamps, ensure that the quarter-turn fasteners are turned fully and secured with a suitable safety cable. The cable must be approved for a safe working load (SWL) of 10 times the weight of the fixture, and it must have a minimum gauge of 3 mm.

3. PREPARING FOR INSTALLATION

Unpack the fixture and inspect it to ensure that it has not been damaged during transport.

The fixture is shipped with two quarter-turn brackets, that can be used to mount the fixture at elevation.

The fixture is IP65-rated, and is designed for use in wet locations. This means that it is protected from:

- Dust, to the degree that dust cannot enter the fixture in sufficient quantities as to interfere with its operation.
- Lower pressure jets of water from any direction.

When selecting a location for the fixture, ensure that:

- It is situated away from public thoroughfares and

protected from contact with people.

- It is not immersed in water or exposed to high-pressure water jets.
- It has adequate ventilation.

4. INSTALLATION

The fixture may be installed in any orientation, but if installed horizontally with a downward beam-angle, water can potentially pool in the fan wells. Under normal operation the moisture will evaporate. However, in locations with high rainfall, you may wish to fabricate a rain shield above the fixture, or modify the position and orientation of the fixture to minimize pooling.

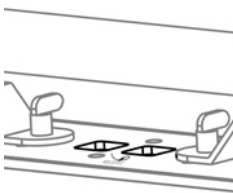

Two quarter-turn brackets are supplied with the fixture if it is to be flown above the ground. Rig the fixture to a support truss or structure using the supplied brackets and suitable clamps.

Fasten a safety cable (not shown) between the support structure and the attachment point on the fixture. The safety cable must be able to bear at least 10 times the weight of the fixture.

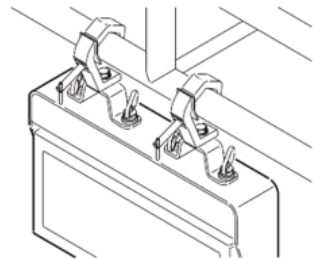

5. CONNECTING AC POWER

The fixture can operate on any 100–240 V, 50/60 Hz

AC mains power supply. It draws approximately 2 amps at full power. For permanent installation, have a qualified electrician wire the mains cable directly to a suitable branch circuit.

The junction's ingress protection (IP) rating must be suitable for the location.

For temporary installation, the mains cable may be fitted with a grounded connector intended for exterior use.

When installing standard type C circuit breakers there will be no limitations due to the fixture in-rush current. Due to the nominal current of the fixture, ensure that no more than:

4 fixtures are connected through the same type C, 10A circuit breaker.

7 fixtures are connected through the same type C, 16A circuit breaker.

The fixture must be grounded/earthed and be able to be isolated from AC power. The AC power supply must incorporate a fuse or circuit breaker for fault protection.

After connecting the fixture to power, run the on-board test, using the "Fixture Test" menu, to ensure that the fixture and each LED are functioning correctly. See "Control menu" on page 13.

CAUTION: Do not open the fixture to replace the supplied power cable, or connect the fixture to an electrical dimmer system, as this can damage it.

6. CONFIGURING THE FIXTURE

Set up the fixture using the control panel and LCD display at the arm side of the fixture.

Navigate the menus and options using the arrow buttons and select items using the Enter button. The

options available are listed in “Control menu” on page 13.

After powering on, the display shows the currently selected operating mode and other information.

The fixture is set by default to be controlled in DMX mode.

MASTER/SLAVE CONFIGURATION

You can set a fixture to operate as master fixture to another fixture (which then becomes a slave fixture), or an entire group of fixtures (which then becomes slave fixtures). The assigned slave fixture(s) will mimic the settings of the master fixture. Use the “Auto Program -> Auto Color / Auto Fade” menu to set your fixture as master fixture, then other fixtures set to DMX mode as slave fixture.

SETTING A STATIC COLOR MANUALLY

The fixture can be configured to display a predefined and static color using the “Manual Color” (see “Control menu” on page 13).

It may suit your needs when you without a DMX controller to do the color mixing.

USING STAND-ALONE OPERATION

Stand-alone operation is where the fixture is not connected to a control device, but is preprogrammed with 2 modes (Auto Color, Auto Fade), that play continuously in a loop, the run speed of “Auto Color”, “Auto Fade” are adjustable.

To define a stand-alone program, use the “Auto Program” menus (see “Control menu” on page 13).

7. CONNECTING TO A DMX CONTROL DEVICE

The fixture is controllable using a DMX control device and it can be connected using a DMX cable. If using a cabled DMX system, connect the DMX in cable (with male 3-pin XLR plug) and out cable (with female 3-pin XLR plug) to the DMX data link. Terminate the DMX out cable of the last fixture in the data link. For outdoor installations, use only IP-rated XLR connectors suitable for outdoor use.

The DMX512 is widely used in intelligent lighting control, with a DMX 512 controller. connect several lights together, DMX in and DMX out, 3 pin XLR connectors: Pin 1: GND, Pin 2: Negative signal (-), Pin 3: Positive signal (+)

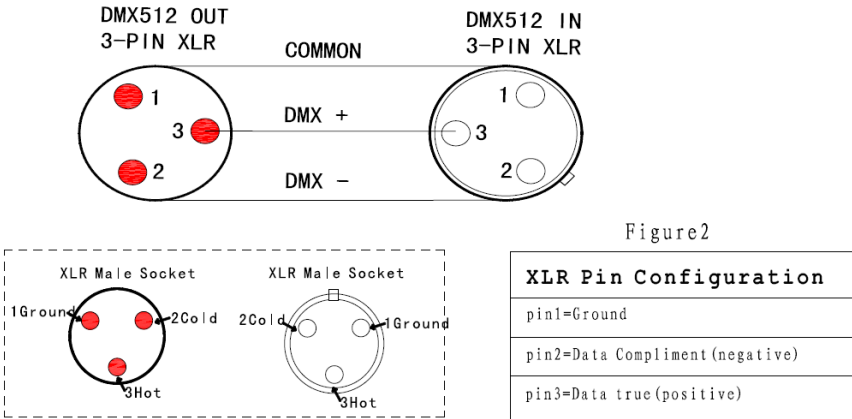

Figure2

8. CONFIGURING THE FIXTURE FOR DMX CONTROL

About DMX

The fixture can be controlled using signals sent by a DMX controller on a number of channels (which varies depending on the DMX mode that has been set).

The first channel used to receive data from a DMX control device is known as the DMX start address.

Each fixture must have a DMX start address set. For example, if a fixture has a DMX address of 10 and it is in 4-channel DMX mode, then it uses channels 10, 11, 12 and 13. The following fixture in the DMX chain could then be set to a DMX address of 14. If two or more DMX fixtures of the same type have the same DMX address, then they will mimic each other's behaviour. Incorrect settings will result in unpredictable responses to the lighting controller.

SETTING THE DMX ADDRESS

The DMX address can be seen on the main screen. To change the address setting, press the up arrow to increase the address, or the down arrow to decrease the setting. When the desired address is displayed, press Enter to save the setting.

Note that channel spacing is determined by the DMX mode.

See the "DMX protocols" on page 11 for specific DMX control values.

SETTING THE DMX MODE

Using the "DMX Channel Mode" menu available from the control panel, specify the DMX mode that provides the fixture controls that you require, confirm chosen mode by pressing 'Enter'.

9. CLEANING

To maintain optimal performance, regular cleaning is essential. Cleaning schedules will vary depending on the operating environment, and the installation should therefore be checked at frequent intervals within the first few weeks of operation to see whether cleaning is necessary. This procedure will allow you to assess cleaning requirements in your particular situation. Clean the fixture using a soft cloth dampened with a solution of water and a

mild detergent. Do not use products that contain solvents, abrasives or caustic agents for cleaning, as they can cause damage to both hardware, cables and connectors.

10. DMX PROTOCOLS

Configuring DMX is described “Setting the DMX mode” on page 10.

Channel		Value	Function
5CH	12CH		
1	1		Tilt :
		0-255	Tilt movement
*	2		Tilt fine:
		0-255	Tilt fine movement
*	3		Dimmer :
		0-255	All dimmer
*	4		Strobe :
		0-5	No function
		6-42	Strobe macro 1
		43-85	Strobe macro 2
		86-128	Strobe macro 3
		129-171	Strobe macro 4
		172-214	Strobe macro 5
215-255	Strobe macro 6		
2	5		Red :
		0-255	Red dimmer
3	6		Green :
		0-255	Green dimmer
4	7		Blue :
		0-255	Blue dimmer

5	8		White :
		0-255	White dimmer
*	9		Auto Macro :
		0-1	No function
		2-45	Full On
		46-115	Color change macro
		116-185	Color fade macro
	186-255	Color pulse macro	
*	10		Color temperature:
		0-255	Warm to cold white
*	11		Tilt Speed:
		0-255	Tilt movement speed from fast to slow
*	12		Dimmer Speed:
		0-255	Dimmer speed from fast to slow

11. CONTROL MENU

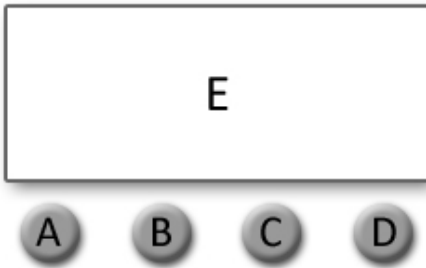

- A. MENU
- B. UP
- C. DOWN
- D. CONFIRM
- E. DIGITAL DISPLAY WINDOW

DISPLAY:

MENU To select the programming functions (press to unlock screen)

DOWN To go backward in the selected functions

UP To go forward in the selected functions

ENTER To confirm the selected functions

SET DMX ADDRESS:

1. Press "**MENU**" to unlock screen, then select the "**DMX Address**" and press "**ENTER**".
2. Showing "**Set DMX Address 001**", Press the "**UP** or "**DOWN**" key to increase or decrease the DMX address value.
- 3 Press "**ENTER**" to save and Exit, Press "**Cancel**" does not save and Exit.

Level 1	Level 2	Description
DMX Address Address	001-512	Set DMX address
DMX Channel Mode	5_CH	5 channels DMX mode
	12CH	12 channels DMX mode
Dimmer Mode	DIM1	Dimmer mode 1
	DIM2	Dimmer mode 2
	DIM3	Dimmer mode 3
	DIM4	Dimmer mode 4
	DIM5	Dimmer mode 5
Mode Selection	DMX512	DMX mode
	Auto1	Auto run mode 1
	Auto2	Auto run mode 2
	Auto3	Auto run mode 3
	Y motor	Tilt movement
	White	White dimmer
	Strobe	Strobe effect
	Red	Red dimmer
	Green	Green dimmer
	Blue	Blue dimmer
System Setting	Language	CH/English
	Bk_Light	OFF/ON
	Dmx512	Clear/Keep
	W-DMX	Link/Unlink (W-DMX version only)

System Info	RDM UID	RDM UID
	Version	Software Version Number
	DMX Channel	Currently used mode

12. SPECIFICATION

TECHNICAL DATA

LED Type: 10W RGBW 4in1 LEDs

LED Count: 44

LED Colors: RGBW

MOVEMENT

Resolution: 8-16 Bit

Tilt (Degrees): 185°

CONTROL

Control Modes: 5CH / 12CH

Display: LCD

Protocol: USITT DMX-512, RDM

RDM: Bidirectional communication

Cooling: temperature controlled, overheating protection

EFFECTS

Dimmer: 0-100% electronic

Dimmer mode: 5 modes

Internal Effects: 3 Color Auto Run Effects

CONNECTORS

Signal connection: Seetronic IP65 XLR 5-Pin or 3-Pin In/Out

Power Input: Seetronic PowerCON TRUE1 In/Out

OPERATING CONDITIONS

Mains voltage: 100-240V AC / 50-60Hz

Power: 400W

Maximum ambient temperature: -30°C / 86°F, 50°C / 122°F

Operating Position: any

MOUNTING OPTIONS

Standing: Body feet

Hanging: Omega-Bracket

Safety wire attachment: foldout eyelets

SHIPPING

Single fixture: cardboard (inner and outer cartons)

Tourpack: 4-way Flight Case

DIMENSIONS & WEIGHT

Length: 482 mm / 18.9 in

Width: 178 mm / 9.0 in

Height (head horizontal): 243 mm / 9.5 in

WEIGHT

N.W: 10 kg

G.W: 12.5 kg

13. PHOTOMETRICS

